

LRRR915 & LRRT915

LONG RANGE RANCH TRANSMITTER & RECEIVER KIT

v.3.15.19



The LONG RANGE RANCH transmitter/receiver kit is a revolutionary product. This product allows for wirelessly triggering a relay through a battery powered hand held transmitter with extreme range, no line-of-sight wireless technology.

WHAT'S INCLUDED

There are two pieces included in the LRRR915 & LRRT915 kit.

HOW IT WORKS...

Congratulations on your purchase of the American Armor Long Range Ranch Transmitter/Receiver kit. It has been designed with state-of-the-art radio technology to provide maximum transmission through obstruction and interference.

The LRRR915 to LRRT915 kit can be easily paired together with the program/learn button on the LRRR915 board. Simply connect the Dry output closure to the device you are triggering and you will be up and running.

The LRRT915 is a send/receiver unit that sends a signal when the button is pressed, indicated by a red LED light. And receives a signal back, indicated by a green LED light. This allows users to know the signal was sent and received by the corresponding LRRR915 unit.

3. TRANSMITTER SPECIFICATIONS

Minimum / Maximum Temperature Range: -40°F to 185°F (-40°C to 85°C)

Security Encryption: AES

Range: 1/2 mile (Through obstructions)

Power: Micro-USB Rechargeable

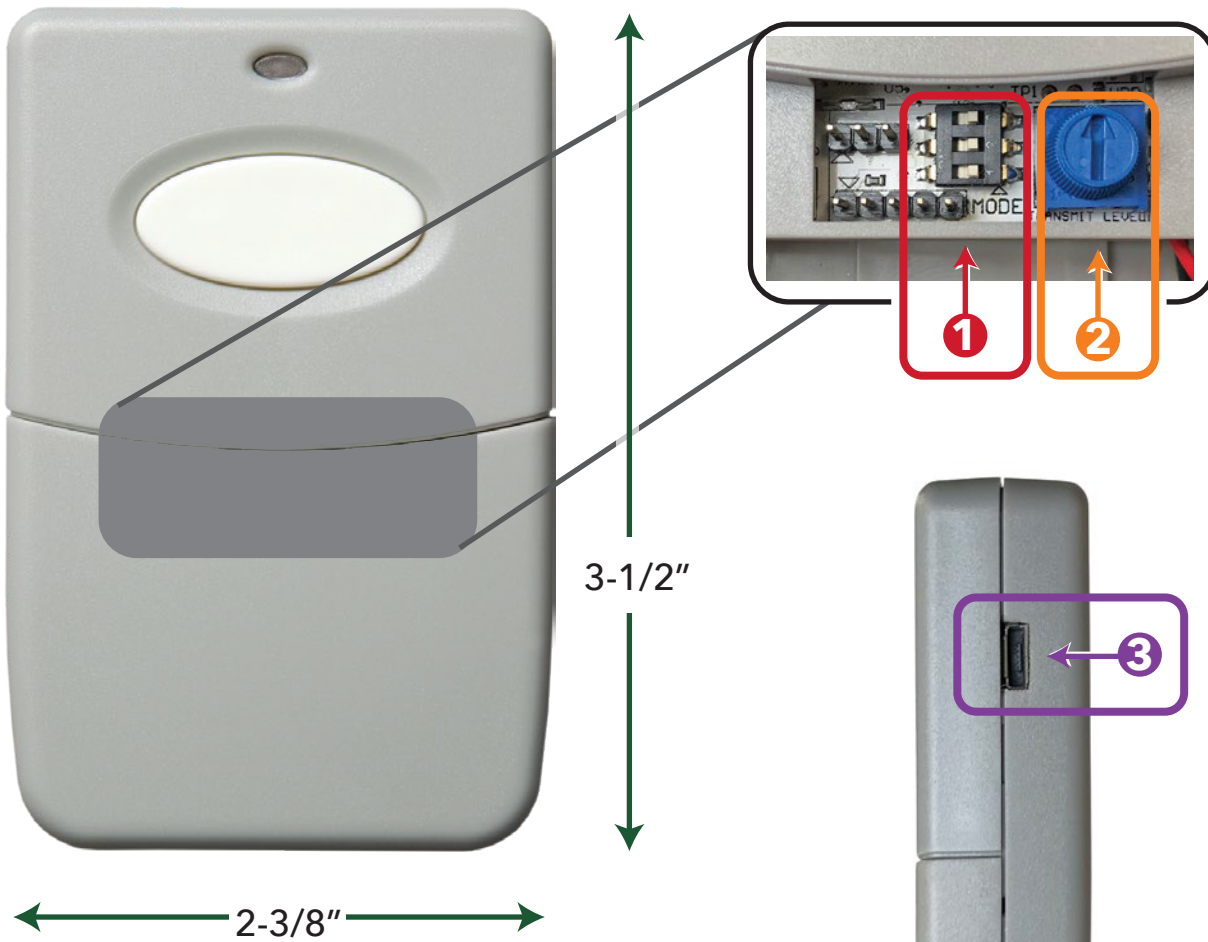

- 1 MODE DIP SWITCHES**
SWITCH 1 – Learn Mode
SWITCH 2 – Not used
SWITCH 3 – Not used

- 2 TRANSMIT LEVEL**
Clockwise for more power when transmitting.
Counterclockwise for less power when transmitting.
(Battery life will vary based on transmit power level set)

- 3 MICRO-USB PORT**

4. POWER DETAILS

The Receiver requires 1 amp of current draw to transmit at full power.

IMPORTANT - Receiver REQUIRES AT LEAST 1AMP POWER SUPPLY

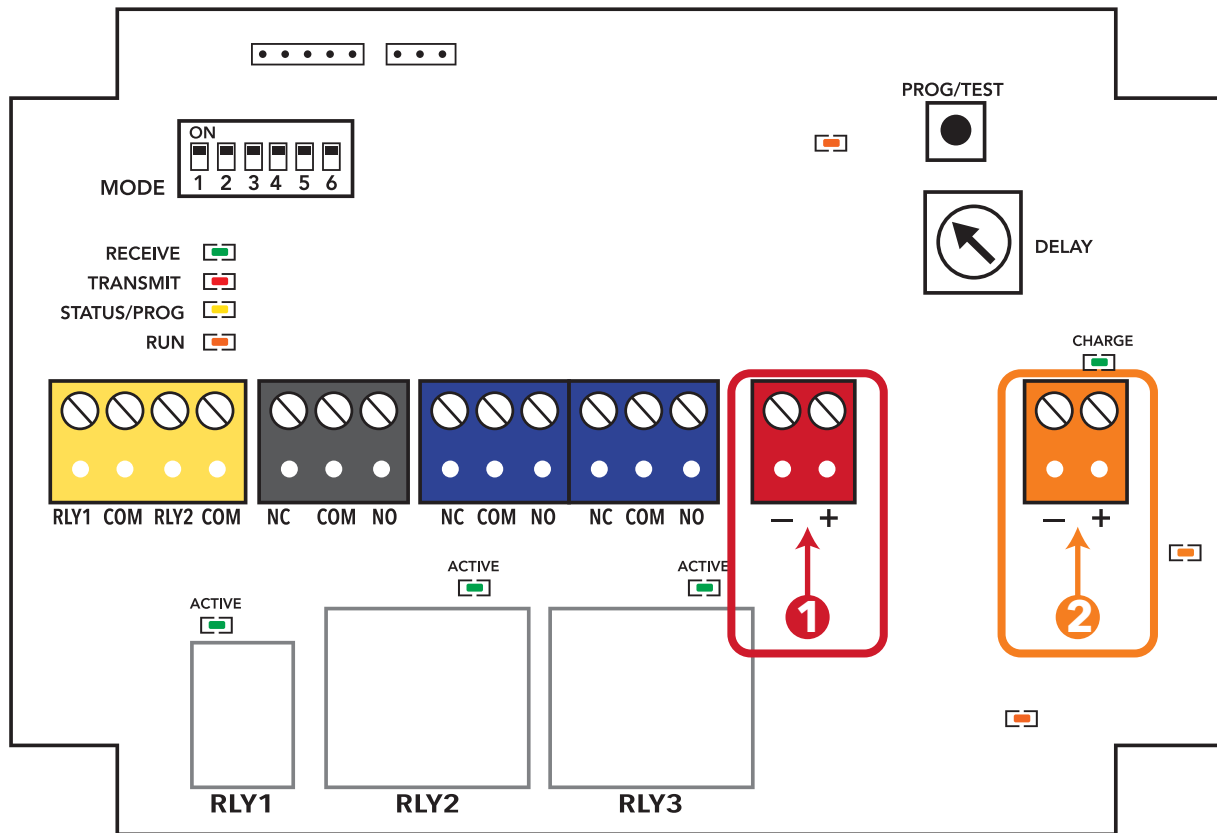

① POWER INPUT:

Power Input: 12 to 24 VOLTS AC/DC. Always follow polarity when DC Power is used. **1 AMP Minimum**

② BATTERY INPUT:

Battery Input: for 12 Volt battery.

Solid Green LED = Battery charging

Momentary Flashing LED = Battery is fully charged and a trickle/conditioning charge is occurring

5. LED INDICATORS

STATUS LEDs:

- 1 RECEIVE** - flashes GREEN momentarily when a valid radio transmission is received.
- 2 TRANSMIT** - flashes RED momentarily when the unit transmits a packet as a result of an Relay Input change event or handshake.
- 3 STATUS/ PROG** - flashes yellow patterns indicating status of the unit: pairing, error, etc.
- 4 RUN** - flashes ORANGE 1 second ON and 1 second OFF indicating the microprocessor is running.
- 5 POWER LED** - Glows solid orange when power is present. 5 volt relay supply, 3.3 volt logic supply, and VPA 3.6 volt power amplifier supply.

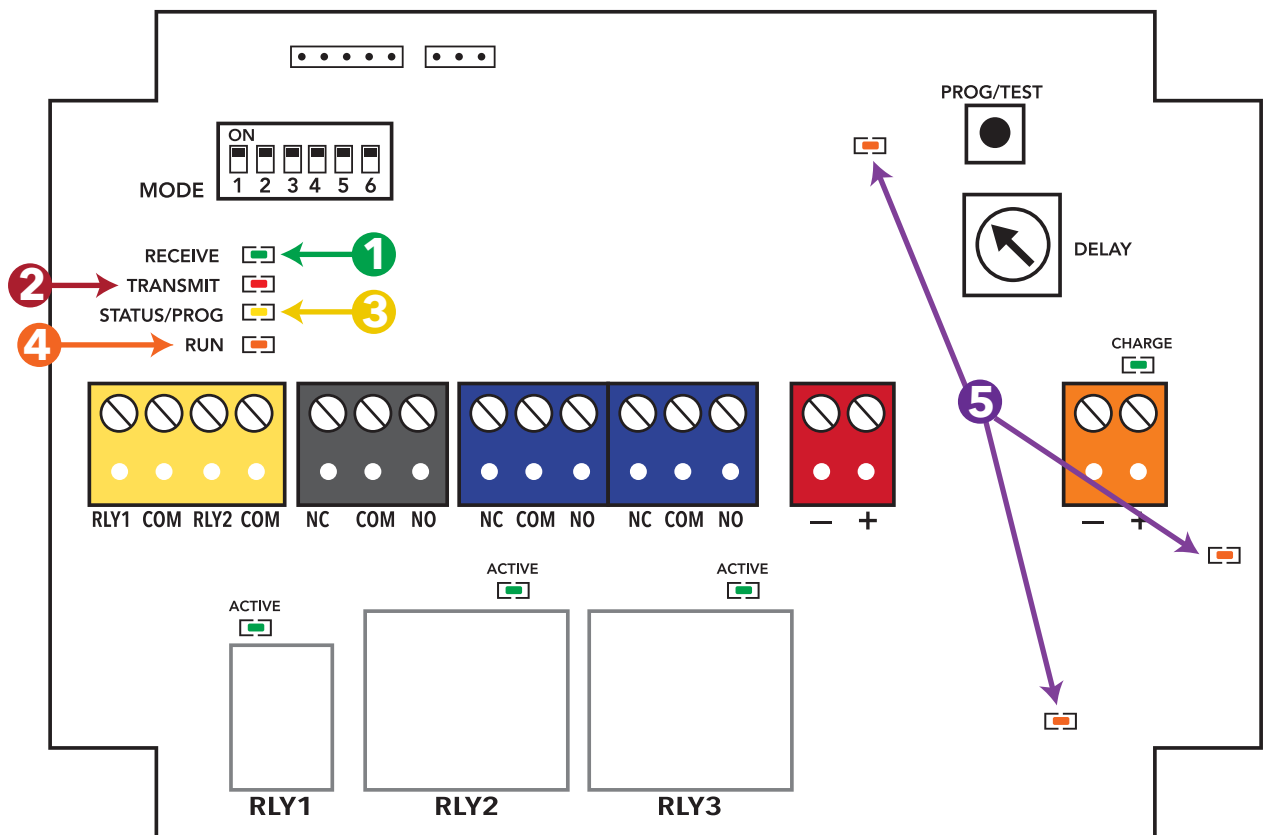

6. RELAY DIAGRAM AND WIRING

1 RELAY OUTPUTS

Relay Outputs - The Receiver come with 2-relay outputs. Both relay 1 and relay 2 can be used as momentary or latching. Please refer to DIP switch settings on page 8 for more information. The relay state is shown with the green active LED above the relay.

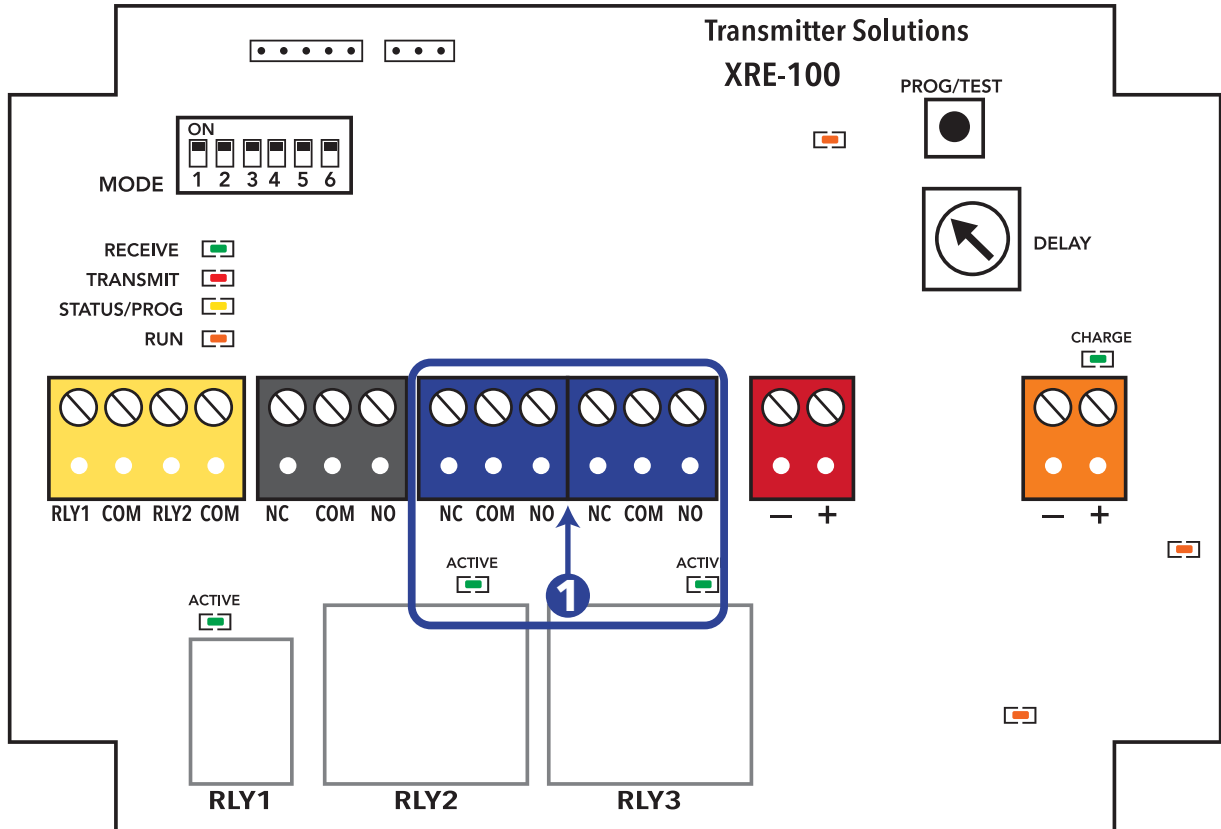

WARRANTY

The warranty period of this product is 24 months, beginning from the manufacturing date. During this period, if the product does not operate correctly, due to a defective component, the product will be repaired or replaced at the sole discretion of American Armor Products. This warranty does not extend to the product casing which can be damaged by conditions outside of the control of American Armor Products.

EXCEPT AS SET FORTH ABOVE, AMERICAN ARMOR PRODUCTS MAKES NO WARRANTIES REGARDING THE GOODS, EXPRESS OR IMPLIED, INCLUDING WARRANTY OF MERCHANTABILITY OR WARRANTY OF FITNESS FOR A PARTICULAR PURPOSE. BUYER MAKES NO RELIANCE ON ANY REPRESENTATION OF AMERICAN ARMOR PRODUCTS, EXPRESS OR IMPLIED, WITH REGARD TO THE GOODS AND ACCEPTS THEM "AS-IS/WHERE-IS". AMERICAN ARMOR PRODUCTS SELLS THE GOODS TO BUYER ON CONDITION THAT AMERICAN ARMOR PRODUCTS WILL HAVE NO LIABILITY OF ANY KIND AS A RESULT OF THE SALE. BUYER AGREES THAT AMERICAN ARMOR PRODUCTS SHALL HAVE NO LIABILITY FOR DAMAGES OF ANY KIND, WHETHER DIRECT, INCIDENTAL OR CONSEQUENTIAL DAMAGES, INCLUDING INJURIES TO PERSONS OR PROPERTY, TO BUYER, ITS EMPLOYEES OR AGENTS, AS A RESULT OF THE SALE. BUYER ALSO AGREES TO HOLD AMERICAN ARMOR PRODUCTS HARMLESS FROM ANY CLAIMS BUYER, OR ANY THIRD PARTY, MAY HAVE AS A RESULT OF BUYER'S USE OR DISPOSAL OF THE GOODS. BUYER HAS READ THIS DISCLAIMER AND AGREES WITH ITS TERMS IN CONSIDERATION OF RECEIVING THE GOODS.



PH 866.975.0101 • FX 866.975.0404
www.transmittersolutions.com